

The Determinant Factors Efficacy of School Based Management (SBM) In Senior High School in All of The Former PATI Residency

Masrukhin,^{a*}

^a *Department of Tarbiyah, Sekolah Tinggi Agama Islam Negeri Kudus, Indonesia*

**Corresponding author: masrukhin@gmail.com*

Article history

Received: 10/10/2016

Received in revised form: 13/1/2017

Accepted: 04/03 /2017

Abstract

The goal of this research is to verify some theory related to the determinant factors efficacy of School Based Management (SBM). This research used survey research by quantitative approach. The technique of taking sample used quota sampling counted 100 from 106 of Senior High school in all of former Pati residency. Those samples were taken by each area amounting to 400 people. The model of this research used SEM in AMOS program. Therefore the relation of full structural model is fit. The result of the sum of influence eksogen variable to endogen variable, that is teacher professionalism is 22,9%, school organization culture is 23,5%, managerial ability of headmaster is 22%, and participation of school committee is 24%. The fourth determinant variables that most contribute to the successful implementation of school-based management in senior high school in all of the former Pati residency is the school committee's participation amounted to 24%, and the lowest is the managerial ability of headmaster by 22%. This is consistent with the theory that the essence of school-based management is the management of educational institutions oriented to the needs and participation of the community in order to empower the school's independence or through the granting of authority, flexibility, and resources to improve the quality of education.

Keywords: SBM, teacher professionalism, School organization culture, managerial ability of headmaster and participation of school committee.

Abstrak

Penelitian ini bertujuan untuk melakukan verifikasi teori berkaitan tentang faktor-faktor penentu keberhasilan pelaksanaan manajemen berbasis sekolah (MBS). Penelitian ini menggunakan jenis penelitian *survey* dengan pendekatan kuantitatif. Teknik pengambilan sampel menggunakan *quota sampling* sebanyak 100 SMA dari 106 SMA di se-Wilayah Eks Karesidenan Pati. Sampel tersebut diambil di setiap daerah yang berjumlah 400 orang. Model yang dipergunakan adalah SEM pada program AMOS. Hubungan struktural model *full SEM* dinyatakan *fit*. Hasil analisis besarnya pengaruh setiap variabel eksogen terhadap variabel endogen adalah Profesionalisme Guru sebesar 22,9%, Budaya Organisasi Sekolah sebesar 23,5%, Kemampuan Manajerial Kepala Sekolah sebesar 22%, dan Partisipasi Komite Sekolah sebesar 24%. Variabel penentu keempat yang paling berkontribusi terhadap keberhasilan pelaksanaan manajemen berbasis sekolah di SMA di se-Wilayah Eks Karesidenan Pati adalah partisipasi komite sekolah sebesar 24%, dan terendah adalah kemampuan manajerial kepala sekolah sebesar 22%. Hal ini sesuai dengan teori bahwa inti dari manajemen berbasis sekolah adalah pengelolaan lembaga pendidikan berorientasi pada kebutuhan dan partisipasi masyarakat dalam rangka memberdayakan kemandirian sekolah atau melalui pemberian kewenangan, fleksibilitas, dan sumber daya untuk meningkatkan kualitas pendidikan.

Kata Kunci: Manajemen Berbasis Sekolah (MBS), profesionalisme guru, budaya organisasi sekolah, kemampuan manajerial kepala sekolah, dan partisipasi komite sekolah

1.0 INTRODUCTION

The policy efforts in the implementation of school-based management (SBM) is in fact, until now there has been sufficient to improve the quality of education services for the general public so as to bring due to the low quality of education. It is heavily influenced by some external and internal factors. According Umaedi (1999) provide an analysis that there are two factors that may explain why efforts to improve the quality of education has been less successful or not. The first strategy is the development of education for more nature oriented input which is a strategy that emphasizes the external factors of education, such as providing books (teaching materials) and other learning tools, provision of education, training of teachers and other education personnel. Second, management of education during this time is more macro-oriented regulated by the bureaucracy at the central level. As a result, many factors are projected at the macro level (the center) is not running properly at the micro level (school).

Based on the foregoing, the researchers are interested in conducting research on the determinants of successful implementation of School Based Management (SBM) in High School (SMA) public and private in all of the former Pati residency.

Based on the research background, as noted above, the problem in this research is to determine how much the teacher professionalism, the school organization culture, the managerial ability of headmaster, the participation of school committee determines the successful implementation of school-based management (SBM) in High School (SMA) public and private in all of the former Pati residency.

2.0 THEORETICAL

2.1 Paradigm School Based Management (SBM)

SBM is the essence of the decision-making autonomy and participation to achieve quality objectives of the school. Decision-making participation start from the assumption that if a person involved in the decision-making process, then the question will feel to have the decision, so that the concerned will be responsible and dedicated fully to achieve the goals of the school. In summary the greater the level of participation, the greater the sense of belonging, the greater the sense of belonging, the greater the sense of responsibility, and a greater sense of responsibility the greater the dedication. School autonomy and participation decisions on quality aims to review the school improvement based on national education policy (Soegito, 2007: 4).

Changes in the pattern dimensions of educational management from the old to the new pattern to the SBM can be described in table 1 as follows:

Table 1. New Paradigm in School Based Management

The old pattern	Head	The new pattern
- Subordination	----->	- Autonomy
- Centralized decision making	----->	- Decision-making participation
- Space motion of rigid	----->	- Flexible space
- The approach of bureaucratic	----->	- A professional approach
- Centralized	----->	- Decentralize
-Be regulated	----->	- Self-motivation
- Over- regulation	----->	- Deregulation
- Control	----->	- Influence
- Direct	----->	- Facilitate
- Evade risks	----->	- Managing risk
- Use the money all	----->	- Use that as efficiently as possible

- Individuals who are intelligent	----->	- Teamwork smart
- Personal information	----->	- Information Divided
- Assignments	----->	- Empowerment
- Organizations herarkis	----->	- Flat organizations

Sources: Umaedi (2000:8)

School based management (SBM) is an autonomous educational policy implementation with regard to the management of educational institutions oriented to the needs and participation of the community in order to empower the school's independence or through the granting of authority, flexibility, and resources to improve the quality of education. The indicators of school based management (SBM) is (1) the quality of schools, (2) autonomy of schools, (3) participatory decision-making, (4) the flexibility of school, (5) empowerment of schools and communities.

2.2 Teacher professionalism

Basic skills no other than the competence of teachers. As revealed by Usman (2000: 14) relating to the competence of teachers (teacher competency) is the ability of a teacher to perform responsibility has or her duties appropriately. Teacher competency is the ability of a teacher to implement the obligations in a responsible and feasible. The professionalism of teachers according Sardiman (1996: 161) is the ability of teachers to design programs and the skills to communicate the program to the students as formulated in ten competence of teachers so that spur learning motivation of the students. Further, in the perspective of the national education policy, the government has formulated four types of teacher competence as specified in the Explanation of Government Regulation No. 19 Year 2005 on National Education Standards, namely: (1) Competence pedagogy is an ability in the management of learners that includes: (a) educational foundation of insight or understanding; (b) understanding of the learners; (c) the development of the curriculum / syllabus; (d) the design; (e) the implementation of learning that educates and dialogue; (f) evaluation of learning outcomes; and (g) the development of learners to actualize various potentials; (2) The personality competence is the ability of personality: (a) steady; (b) stable; (c) adult; (d) the wise and prudent; (e) authoritative; (f) morality; (g) become role models for students and the community; (h) evaluating its own performance; and (i) to develop self-sustainable manner; (3) Social competence is the ability of educators as part of the community to: (a) communicate orally and in writing; (b) using information and communication technology functional; (c) interact effectively with students, fellow teachers, staff, parents / guardians of students; and (d) mingle politely with the surrounding community; and (4) Professional competence is the ability to master the learning materials widely and deeply that includes: (a) the concept, structure, and methods of science / technology / art houses / coherent with the teaching materials; (b) teaching materials that exist in the school curriculum; (c) the relationship between the concepts related subjects; (d) the application of scientific concepts in everyday life; and (e) in a professional competition in a global context while preserving national values and culture.

2.3 School Organization Culture

Culture can be seen in the form of people's behavior, which is the result of thought and reflected in the attitudes and actions. Tasmara (2002: 161) states that the essence of culture, namely: (a) culture is closely related to the perception of value and the environment that gave birth to the meaning and philosophy of life that would influence the attitudes and behavior (the total way of life a people), (b) their pattern of values, attitudes, behavior (including language), the work and initiative, including any instrument, work systems and technology (a way thinking, feeling, and believing), (c) culture is the result of life experiences, habits, as well as the selection process (accept or reject) the norms that exist in the way she interacts socially or put himself in the middle of a particular environment, (d) in the process of culture there is interplay and interdependence, social and environmental nonsocial.

School organizational culture can be classified into two that are visible (tangible) and does not appear (intangible). Aspects that are not visible from a culture includes values, beliefs, and ideologies related to the question "What should be done in this school?" The answer is manifested in tangible things (are shown) in the form of a sentence (oral or written), the behavior displayed, buildings, facilities as well as objects used (Caldwell and Spinks, 1993).

With reference to the Fred thought Luthan (1995) in Sudrajat (2008) says that the characteristics of the organizational culture in schools, namely (1) observed behavioral regularities; (2) norms; (3) the dominant value; (4) philosophy; (5) rules and (6) organization climate

2.4 Managerial ability of headmaster

Management is a process of managing existing resources has four functions: planning, organizing, monitoring, and evaluating. This is in accordance with the opinion of Terry in Sutopo stating that management functions include planning, organizing, and monitoring is done to achieve the goals that have been set through the utilization of human resources and other resources (Sutopo, 1999: 14).

Duties and responsibilities of the head of school / madrasah as a top leader as stated Burhanuddin (1994: 29) that the duties and responsibilities of the headmaster is to plan, organize, direct, coordinate, monitor and evaluate all activities of the school / madrasah, which includes the field of teaching and learning process, office administration, student administration, personnel administration, administrative supplies, financial administration, the library administration, and the administration of public affairs. Therefore, in order to achieve organizational goals, headmaster/madrasah basically have a duty and responsibility for planning, organizing, and control all existing resources and activities carried out in schools/madrasah. In order to achieve the educational goals of the headmaster/madrasah to perform the duties and responsibilities of the head of school / madrasah needs to have many of the capabilities needed. According to Katz was quoted as saying by Sudarwan Danim (2002) says that the managerial capabilities include technical skills (technical ability), human skill (the ability of human relationships), and conceptual skills (conceptual abilities).

2.5 Participation of School Committee

The school committee is an umbrella organization which holds formal public participation in the implementation of educational development. In terms of development management, community participation in development by Muhadjir (1983: 34) can be divided into three phases: (1) planning, (2) the implementation phase, and (3) the deployment phase. Participation in decision making will increase, when people understand the intent and scope an innovation; thus enhance the effectiveness of its implementation (Stahl, 1972: 6-8). Familiarize take decisions collectively with diverse competencies will help create the atmosphere to increase institutional participation.

SBM is a new concept that is in line with the policy of decentralization in governance paradigm. In order to achieve the goals of national education through improving quality, educational equity and efficiency of achievement of the democratization of education, the need for support and participation of the public is more maximum. As a consequence, the government has issued Kepmendiknas No. 044 / U / 2002 on the Board of Education and the School Committee. The School Committee is an independent body that embodies the role of the community in order to improve quality, equity and efficiency of education management in the Education Unit well in preschool education, education track or path outside of school education. School Committee role and function as (1) giving consideration (advisory agency) in the determination and implementation of educational policy in the education unit, (2) support (supporting agency) both tangible financial, thought and effort in providing education in the education unit, (3) controlling (controlling agency) in the framework of transparency and accountability in the delivery of education and educational outcomes in the education unit, (4) a mediator between the government (executive) with the community in the

education unit. The school committee works as follows: (1) Encouraging the growth of the attention and commitment of the community towards the implementation of quality education, (2) working with the community (individual / organization / business / industry) and the authorities with regard to the implementation of quality education, (3) accommodating and analyze the aspirations, ideas, demands and various needs of education offered to community, (4) provide input, consideration and recommendation to the education units regarding: (a) policy education program, (b) Plan of Education Budget and Expenditure School (RAPBS), (c) criteria for the performance of the education unit, (d) the criteria of education personnel, (e) the criteria of educational facilities, (f) other matters related to education, (5) to encourage parent and community involvement in education in order to support the improvement of the quality and equity of education, (6) to raise funds in order to finance public education in the education unit, (7) the evaluation and supervision of the policies, programs, organization, and education outcomes in the education unit (Kepmendiknas, 2002: 122-123).

2.6 Research Paradigm

This study researchers only limit on several variables successful implementation of SBM specified by the teacher professionalism, school organization culture, managerial ability of headmaster and participation of school committee with this assumption is based on the implementation of the SBM that have been conducted in Senior High School in all of the former Pati residency. In the implementation of SBM experience various obstacles, whether it is coming from outside the school as well as internally in the school. From a logical framework below, then made the research paradigm as in figure 1.

2.7 Formulation Research Hypothesis

The working hypothesis of research are: successful implementation of School Based Management (SBM) is determined by the teacher professionalism, school organization culture, managerial ability of headmaster and participation of school committee in high school (SMA) public and private in Senior High School in all of the former Pati residency.

3.0 RESEARCH METHODS

3.1 Type Approach and Design Research

Object of this research study using a quantitative research design paradigm. This research use descriptive research and verification methods in the context of confirmatory survey are: the study describes causal relationship variables through hypothesis testing. Second model approach order Confirmatory Factor Analysis. The analysis tool used is structural equation modeling (SEM).

3.2 Research Variable

Exogenous latent variable is the independent variable is expressed by the Greek letter ξ (ksi), while the endogenous latent variable is the dependent variable (dependent variable) is expressed by the Greek letter η (eta). Exogenous latent variables there are four, namely teacher professionalism (ξ_1), school organization culture (ξ_2), managerial skills of principals (ξ_3) and participation of school committee (ξ_4). No one endogenous latent variables, namely the successful implementation of school-based management (SBM), which is expressed by the Greek letter (η).

3.3 Location Research

The location of this research conducted in educational institutions at the secondary level that is high school in all of the former Pati residency either SMA or SMA Private by taking samples at locations SMA that is considered representative scattered in five districts of Kudus Regency, Regency Jepara, Pati regency, Blora Regency and Rembang Regency.

Figure 1: Research Paradigm Determinants SBM

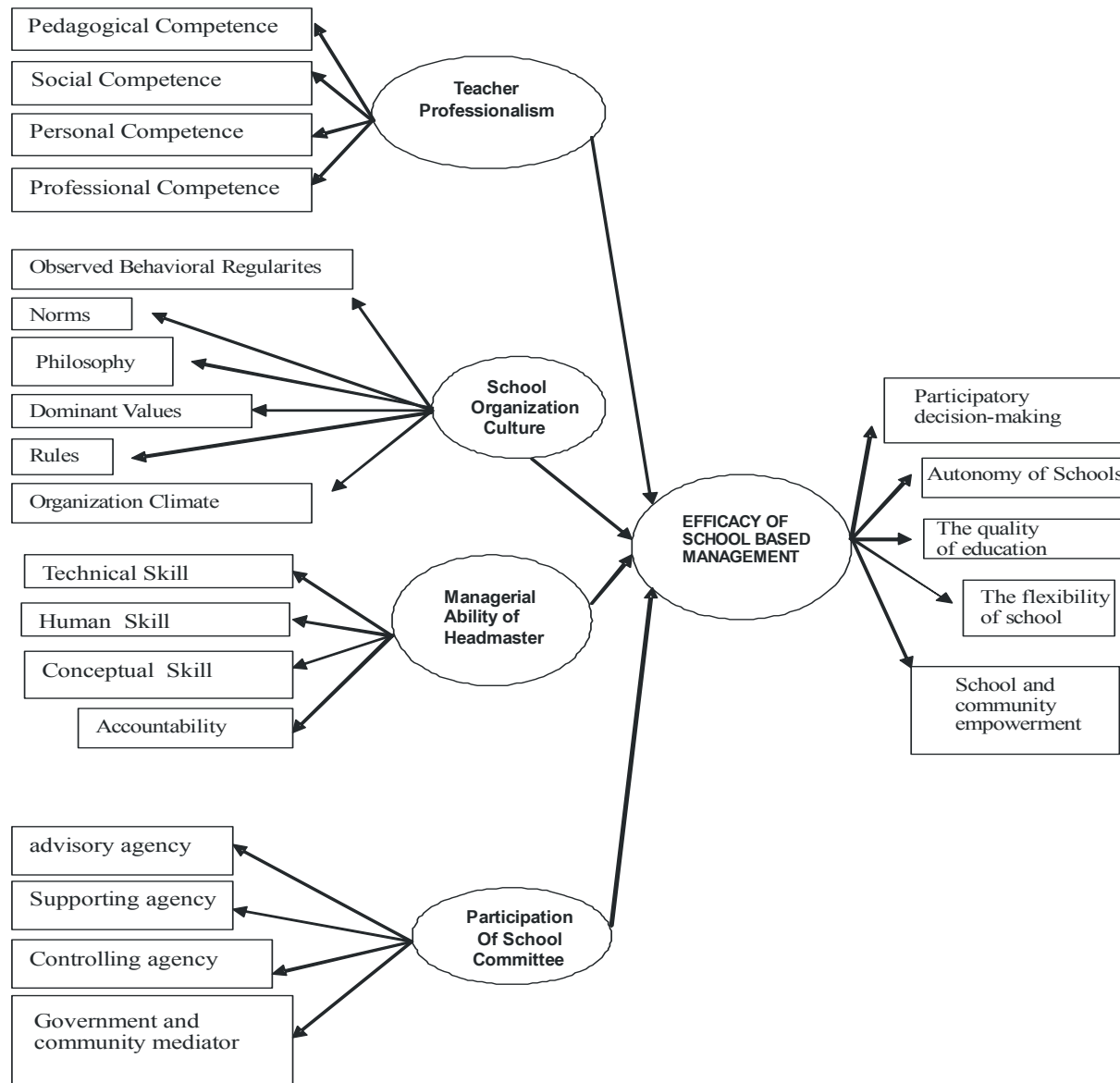

3.4 Population and Sampling Techniques

This study uses the unit of analysis is the school. It is based on the assumption that the variable success of school-based management (SBM) is determined by the variance at the group level is not an individual level. School (SMA) public and private in all of the former Pati residency. The unit of analysis in schools, 106 high school there. But in the conduct of research in the field is only 100 schools that serve as the unit of analysis. The next procedure that every school that has been designated as a unit of analysis of samples taken using a quota sampling technique sample size of 400 respondents.

3.5 Data analysis technique

Data were analyzed descriptively each variable. Data analysis technique is done with the help of a computer program that is AMOS. If the expected classical statistics is rejecting the null hypothesis, in AMOS contrary that is to accept the null hypothesis. Structural equation modeling consists of two models, namely the structural model and the measurement model (SantosoWijanto, 2014: 10).

4.0 RESULT AND DISCUSSION RESEARCH

4.1 Research Result

Research carried out by spreading 400 (four hundred) copies of questionnaires to 400 respondents in educational institutions in Senior High School in all of the former Pati residency consisting of 100 public and private high school of 106 high school there. The results of descriptive statistical analysis on the variables that influence the successful implementation of school based management (SBM) is teacher professionalism in the variable mean value of 75.54 by the professionalism of teachers enough categories of professional, school organizational culture mean value of 90.30 with good enough category. Managerial ability of headmaster mean of 54.01 with good enough category. Participation of school committees mean value of 66.44 by category quite well. The successful implementation of school-based management, mean value of the successful implementation of MBS amounting to 74.12 with the category quite well.

4.2 Analysis of Structural Equation Model (SEM)

Visualization hypothesis by using flowcharts (path diagram) have been tested and can be illustrated in the figure 2.

Figure 2: Structural Equation Model (SEM)

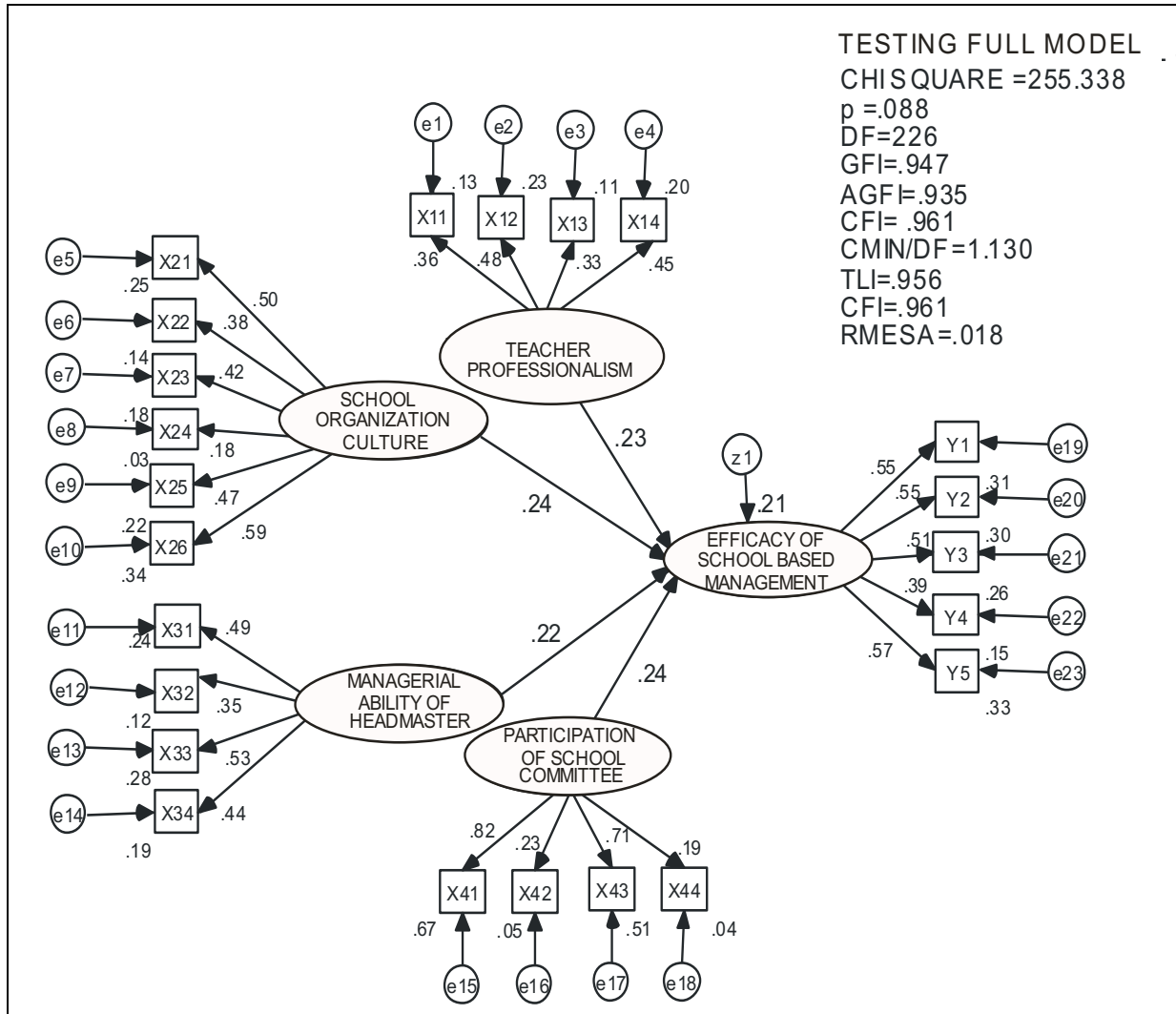

Table 2. Regression Coefficients Calculation Results SEM Analysis

Effect	Estimate	SE	CR	P
X14 ← Teacher Professionalism	0,453	0,239	3,524	0,002
X13 ← Teacher Professionalism	0,331	0,298	3,217	0,001
X12 ← Teacher Professionalism	0,476	0,249	3,125	0,000
X11 ← Teacher Professionalism	0,359			
X26 ← School Organization Culture	0,585	0,193	4,473	0,000
X25 ← School Organization Culture	0,474			
X24 ← School Organization Culture	0,180	0,180	2,622	0,009
X23 ← School Organization Culture	0,420	0,249	4,952	0,000
X22 ← School Organization Culture	0,378	0,269	5,300	0,000
X21 ← School Organization Culture	0,505	0,220	5,229	0,000
X34 ← Managerial Ability of Headmaster	0,436	0,197	4,248	0,001
X33 ← Managerial Ability of Headmaster	0,528			
X32 ← Managerial Ability of Headmaster	0,345	0,102	3,914	0,008
X31 ← Managerial Ability of Headmaster	0,495	0,122	4,710	0,001
X44 ← Participation of School Committee	0,193			
X43 ← Participation of School Committee	0,712	1,872	3,218	0,000
X42 ← Participation of School Committee	0,226	0,421	2,652	0,000
X41 ← Participation of School Committee	0,821	1,145	3,294	0,000
Y ₅ ← Efficacy of School Based Management (SBM)	0,572			
Y ₄ ← Efficacy of School Based Management (SBM)	0,392	0,161	6,637	0,000
Y ₃ ← Efficacy of School Based Management (SBM)	0,509	0,154	6,600	0,000
Y ₂ ← Efficacy of School Based Management (SBM)	0,546	0,141	5,376	0,000
Y ₁ ← Efficacy of School Based Management (SBM)	0,553	0,160	7,242	0,000

Sources: Primary data the processed

4.3 Hypothesis testing

Test results the hypothesis testing are as follow:

Hypothesis 1: The successful implementation of school based management (SBM) is determined by the professional teacher in senior high school in all of the former Pati residency - **be accepted**.

Hypothesis 2: The successful implementation of school based management (SBM) is determined by the school's organizational culture in senior high school in all of the former Pati residency - **be accepted**.

Hypothesis 3: The successful implementation of school based management (SBM) is determined by the managerial ability of headmaster in senior high school in all of the former Pati residency - **be accepted**.

Hypothesis 4: The successful implementation of school based management (SBM) is determined by the participation of school committee in senior high school in all of the former Pati residency - **be accepted**.

4.4 Determinants of successful implementation of school-based management (SBM)

The influence of total variable exogen againts endogenous variable appropriate models that have been tested, that influence directly.

Table 3. The influence of Total and direct

Variable	Teacher professionalism	Organizational culture school	The managerial capabilities of the principal	School committee participation
MBS	0,229	0,238	0,220	0,240

Based on the analysis by SEM to construct regression coefficient discussions were held as follows:

- 1 Effect of the most constructive construct variable professionalism of teachers is the dimension of social competence (X_{12}), with estimated value of 0.530. This means that the dimensions of social competence (X_{12}), able to explain at 0.530 and the rest is $1 - (0.530)^2 = 1 - 0.2809 = 0.7191$ or 71.91% were influenced by other variables studied. The variable constructs professionalism of teachers who have no major influence is the pedagogical (X_{11}) of 0.370, personal competence (X_{13}) of 0.300, and professional competence (X_{14}) of 0.420. For teachers pedagogical, personality, and professional is the absolute ability for a teacher and not considered special when compared with social competence that does not have a great impact.
- 2 Effect of the most constructive construct variable dimensions of organizational culture of the school is the organizational climate (X_{26}), with estimated value of 0.560. This means that the dimensions of organizational climate (X_{26}), able to explain at 0.560 and the rest is $1 - (0.560)^2 = 1 - 0.3136 = 0.6864$ or 68.64% were influenced by other variables studied. The construct of cultural variables organizations other schools that do not have a large influence is Obeserved behavioral regularities (X_{21}) of 0.520, Norms (X_{22}) of 0.390, Dominant values (X_{23}) of 0.420, Philosophy (X_{24}) of 0.180, and Rules (X_{25}) of 0.490. For students, teachers, principals and employees Obeserved behavioral regularities, Norms, Dominant values, Philosophy and Rules are regularity act that should be done every citizen in the school were taken from the norm and philosophical value cultural and specified in the regulations at the school in bentutk governance school discipline, which is binding on all citizens and are not considered special schools even a routine action when compared to building an organizational climate that is not easy to be realized in an instant, will still require a continuous process.
- 3 Effect of the most constructive construct variable of managerial ability of headmaster is the skill conceptual dimension (X_{33}), with estimated value of 0.540. This means that the dimensions of conceptual skill (X_{33}), able to explain at 0.540 and the rest is $1 - (0.540)^2 = 1 - 0.2916 = 0.7084$ or 70.84% were influenced by other variables studied. The constructs variable managerial skills of school principals who have no major influence is (1) technical skill (the ability of the technique) (X_{31}) of 0.510, (2) human skills (the ability of human relations) (X_{32}) of 0.330, and accountability (X_{34}) at 0.430 is the managerial skills of the principal that has been done by the head of each school and are not considered to have the power to reform the school to change the school better, advanced and qualified. Headmaster are able to make different concept of school reform and socialize, it is needed in leadership at the school. Moreover, at the present time the school more oriented towards international schools (SBI), a much-needed school principal who has the ability to change adaptive, innovative and creative in implementing all activities towards the goal ideals in schools that aspire together.
- 4 Effect of the greatest constructive participation variable construct school committee is advisory agency dimension (X_{41}), with estimated value of 0.830 means that the dimensions of the advisory agency (X_{41}), able to explain at 0.830 and the rest is $1 - (0.830)^2 = 1 - 0.6889 = 0.3111$ or 31.11% were influenced by other variables studied. The construct of the

variable participation of committees other schools that do not have a large influence is supporting (supporting agency) (X_{42}) of 0.220, controlling (controlling agency) (X_{43}) of 0.710, a mediator between the government (executive) (X_{44}) of 0.190 is the participation of school committees that has not been done by any school committee to the fullest. However, the role of the school committee in controlling framework of transparency and accountability in the delivery of education and educational outcomes in education units have performed well when compared with the role as a mediator between the supporters and the government. The school committee has not acted as a mediator between government supporters and in improving the quality of education that need a wide range of educational facilities were adequate. For example, not maximal school committee be a good support in realizing the financial, thought and effort in providing education in the education unit, and a mediator between the government and the community in the education unit.

- 5 Effect of the most constructive construct variables of successful implementation of school-based management (SBM) is the dimension of the school and community empowerment (Y_5), with estimated value of 0.590. This means that the dimensions of empowerment of schools and communities (Y_5), able to explain at 0.590 and the rest is $1 - (0.590)^2 = 1 - 0.3481 = 0.6519$ or 65.19% were influenced by other variables studied. The construct of variables successful implementation of school-based management (SBM) others who do not have a large influence is participative decision-making (Y_1) of 0.560, school autonomy (Y_2) amounted to 0.500, the quality of education (Y_3) of 0.540, and the flexibility of school (Y_4) of 0.390. This looks participatory decision-making, autonomy of schools and school quality is the dimension that also make a significant contribution to the success of the implementation of school-based management (SBM) to improve the overall quality of education. However, the flexibility of schools have not been able to contribute to the successful implementation of school-based management (SBM). This is because the management of educational institutions in the school is still characterized by a strong bureaucratic system by a local agency with a lot of rules that must be met, thus setting priorities in accordance with the conditions of school less attention. As a result in the development of the school has not been in line with expectations and requirements desired by the community based educational problems faced.

5.0 CONCLUSIONS, IMPLICATIONS AND SUGGESTIONS

Based on the results of descriptive statistical analysis largely exogenous and endogenous latent variables based on the mean value (average value) is included in the category quite well. The theoretical model is built on a grand theory about the determinants of successful implementation of SBM backed by empirical data. This is evident from the results of hypothesis testing in the full model Structural Equation Model (SEM) declared fit. Based on the analysis the level of influence of each exogenous variables on endogenous variables and donations indicators constructs in the determinants of successful implementation of school-based management (SBM) in High School (SMA) public and private in all of the former Pati residency. There is a direct influence of variables professionalism of teachers to the successful implementation of school-based management (SBM) of 0.229, or 22.9%, the organizational culture of the school to the successful implementation of school-based management (SBM) of 0.238, or 23.8%, managerial ability of headmaster to the successful implementation of school-based management (SBM) of 0.220 or 22%, and the participation of school committees to the successful implementation of school-based management (SBM) of 0.240 or 24%.

5.1 Implications

Based on the results of descriptive and inferential statistical analysis of the successful implementation of SBM is determined by several factors deciding the following order:

- 1 The theoretical implications associated with the theory of school-based management (SBM), that the participation of school committees, principals managerial ability, professionalism of teachers and school organizational culture within the framework of general management and management education in particular, should get a priority in the implementation of management school-based (SBM) in the school both substantial, and methodologically. Substantially theory managerial ability, professionalism, organizational culture and community participation should be getting attention in managing educational institutions based on the school. Methodologically principals should have the managerial capability in managing educational institutions. Teachers in teaching and learning process should have the competency required. The school environment should foster an organizational culture within the framework of the academic community to make every human becomes continuous learner (learning continuity). Educational institutions should provide the opportunity for public participation in management to improve the quality of education to be involved in the school committee or board of education.
- 2 Implications in practice - The successful implementation of school-based management in each school will be able to improve the competitiveness of graduates in the world of education and the world of work. Therefore, developers and managers of educational institutions should consider the following matters:
 - a. Improving the quality of education should be based on the empowerment of schools and communities.
 - b. The creation of a pleasant school organizational culture and environment that is conducive to learning and teaching in schools.
 - c. Increased participation of school committees in the activities of implementation of educational programs, especially in providing the considerations in order to improve the quality of education.
 - d. Improving the professionalism of teachers through social competence in order to improve social interaction among fellow colleagues through a variety of education and training related to improving the quality of learning and access to information about science.
 - e. Improved managerial skills of school principals especially conceptual abilities in order to improve the competitiveness of education in the global era. Thus creating a leadership that is visionary, innovative, creative and adaptive.

REFERENCES

- Burhanuddin. (1994). *Analisis Administrasi, Manajemen dan Kepemimpinan Pendidikan*, Jakarta: Penerbit Bumi Aksara.
- Caldwell, B.J. & J. M. Spinks. (1993). *Leading the Self-Managing School*. London, Washington: The Falmer Press.
- Danim, Sudarwan. (2002). *Inovasi pendidikan: Dalam Upaya Peningkatan Profesionalisme Tenaga Kependidikan*. Bandung: Pustaka Setia.
- Danim, Sudarwan. (2003). *Menjadi Komunitas Pembelajar*. Jakarta : Bumi Aksara.
- Depdiknas. (2003). *Konstruk dan Indikator Kualitas Sekolah*. Jakarta : BASNAS Depdiknas.
- Depdiknas. (2003). *Peraturan Pemerintah Nomor 19 Tahun 2005 tentang Standar Nasional Pendidikan (SNP)*. Jakarta : Sinar Grafika.
- Depdiknas. (2002). *Kepmendiknas No. 044 / U / 2002 tentang Dewan Pendidikan dan Komite Sekolah*. Jakarta: Depdiknas.
- Katz, R. (1995). *Is Reengineering Already Dead?* <http://www.ed.gov/-databases/-ERICDigests/ed406962.html>. Quality Digest. (10 Januari 2009).
- Luthans, Fred. (1995). *Organizational Behavior*. Japan: Mc Graw-Hill Company.
- Muhadjir, Noeng. (1983). *Kepemimpinan Adopsi Inovasi untuk Pembangunan Masyarakat*. Yogyakarta: Rake Sarasin.
- Sardiman, A.M. (1996). *Interaksi dan Motivasi Belajar Mengajar Pedoman Bagi Guru dan Calon Guru*, Jakarta : Raja Grafindo Persada.
- Soegito. (2007). *Ujian Nasional (UN) Versus Kebijakan Manajemen Berbasis Sekolah*. Makalah disampaikan pada Forum Komunikasi Pendidikan di Balitbang Depdiknas, 29 Mei.
- Stahl, Richard Layne, John. (1972). *Teacher Participation and Attitudes, Innovation Caharacteristic and the Adoption of Behavioral Objectives, Ph. D. thesis*, The Florida State, University Microfilms International, Ann Arbor, Michigan.
- Sudrajat, Ahmad. (2008). *Budaya Organisasi di Sekolah*. <http://akhmadsudrajat.wordpress.com>. (1 Januari 2008).
- Sutopo. (1999). *Administrasi, Manajemen dan Organisasi*. Jakarta: Lembaga Administrasi Negara.
- Santoso Wijayanto. (2014). *Modul Pelatihan SEM*. Yogyakarta : UGM.
- Tasmara, Toto. (1995). *Etos Kerja Pribadi Muslim*. Jakarta : Raja Grafindo Persada.
- Umaedi. (2000). *Manajemen Peningkatan Mutu Berbasis Sekolah*. Jakarta : Direktorat Pendidikan Menengah.
- Umaedi. (1999). *Manajemen Peningkatan Mutu Berbasis Sekolah*. Jakarta: Direktorat Pendidikan Menengah Umum. <http://www.ssep.net/director.html>. (8 Agustus 2008).
- Usman, Uzer, M. (2000). *Menjadi Guru Profesional*. Bandung: Rosdakarya.